



**40 GHz SMA 2.9 fem LATCHING TRANSFER SWITCH**

OPTIONS: / TTL DRIVE

**R F CHARACTERISTICS**

FREQUENCY RANGE : 0 - 40 GHz  
 IMPEDANCE : 50 Ohms

FREQUENCY (GHz)	0 - 6	6 -12.4	12.4- 18	18 -26.5	26.5- 40
V.S.W.R <=	1.30	1.40	1.50	1.70	1.90
INSERT. LOSS <=	0.30 dB	0.40 dB	0.50 dB	0.70 dB	0.80 dB
ISOLATION >=	70 dB	60 dB	60 dB	55 dB	50 dB
AVER. POWER (*)	80 W	60 W	50 W	20 W	10 W

**ELECTRICAL CHARACTERISTICS**

ACTUATOR : LATCHING  
 NOMINAL CURRENT AT 25°C (±10%) : 320 mA  
 ACTUATOR VOLTAGE (Vcc) : 12V (10.2 to 13V)/ NEGATIVE COMMON  
 TERMINALS : solder pins (250 Deg.C max./30 sec)  
 TTL INPUTS (E) - High level : 2.2 to 5.5V / 800µA at 5V  
 - Low level : 0 to 0.8V / 20µA at 0.8V

**MECHANICAL CHARACTERISTICS**

CONNECTORS : SMA 2.9 fem per MIL C 39012  
 LIFE : 2.500.000 cycles  
 SWITCHING TIME (nominal voltage;25°C) : < 15 ms  
 CONSTRUCTION : splashproof  
 WEIGHT : < 85 g

**ENVIRONMENTAL CHARACTERISTICS**

OPERATING TEMPERATURE RANGE (°C) : -40 , +85  
 STORAGE TEMPERATURE RANGE (°C) : -55 , +85

(\* : average power at 25°C)

This information is given as an indication. In the continual goal to improve our products, we reserve the right to make any modifications judged necessary

4112-9212

**DRAWING**

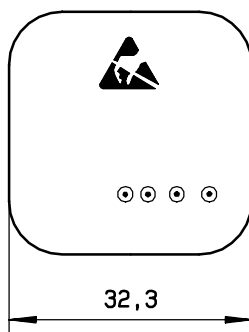
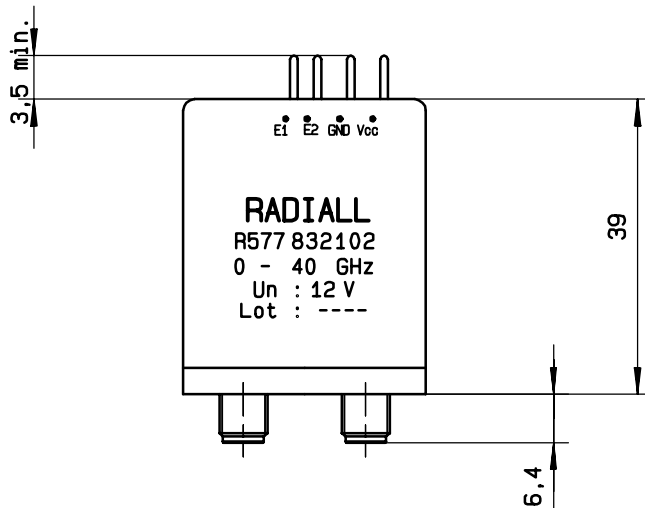
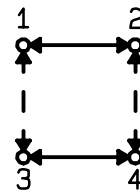
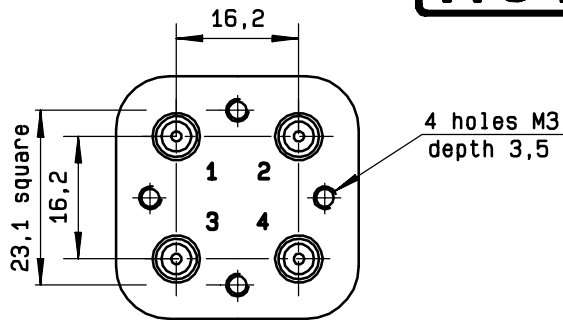

General tolerance: ± 0,5 mm

**SCHEMATIC DIAGRAM**

TTL input	RF continuity
E1=1   E2=0	1↔3 2↔4
E1=0   E2=1	1↔2 3↔4
E1=0   E2=0	Memory
E1=1   E2=1	Forbidden

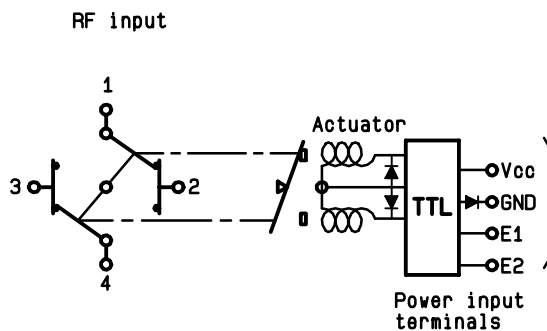

4113-9212 This information is given as an indication. In the continual goal to improve our products, we reserve the right to make any modifications judged necessary